

■ HIGHFIELD around the globe  
Contact details by country at: [www.highfieldboats.com](http://www.highfieldboats.com)

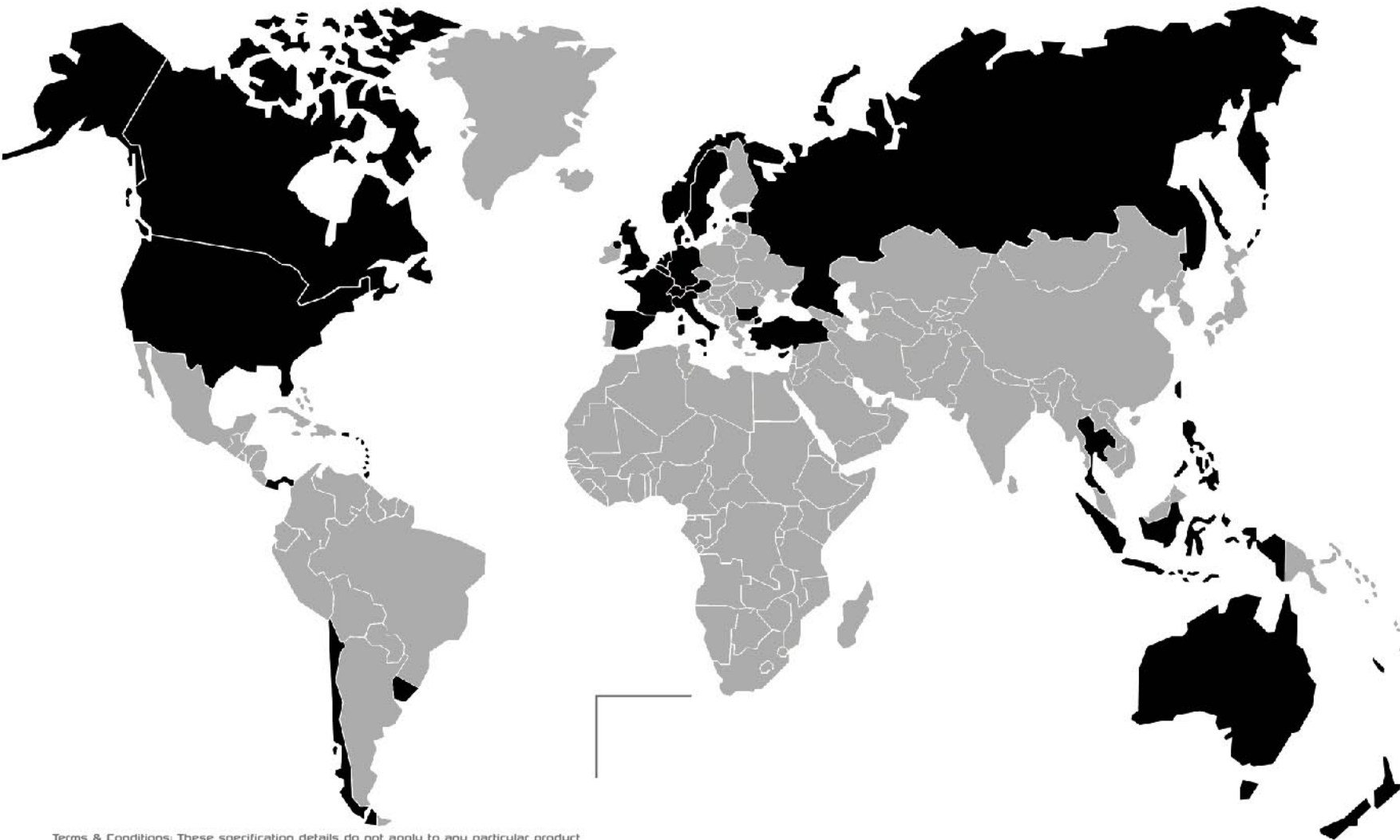

Terms & Conditions: These specification details do not apply to any particular product which is supplied or offered for sale. The manufacturer reserve the right to vary their specification, including colours, with or without notice at such times in such manner as they think fit. Major as well as minor changes may be involved. Every effort, however, is made to ensure the accuracy of the particulars contained in this brochure. Consult the Dealer with whom your order is placed for details of the specification of any particular product. This publication shall not constitute in any circumstances whatsoever an offer by the Company to any person. All sales are made by the Distributor or Dealer concerned subject to and with the benefit of the standard Conditions of Sale and Warranty given by the Distributor or Dealer, copies of which may be obtained from him on request.

2015/1/15



# ENJOY

Highfield inflatables have evolved from over 25 years of development in some of the toughest conditions in the world – the Great Barrier Reef of tropical Northern Australia. As direct descendants of the aluminium hulled Australian Swift range of commercial RIBs, they're tough, reliable and thoroughly tested.

Aluminium has long been the hull material of choice in many parts of the world due to its strength, ease of repair, versatility and above all its weight saving characteristics. Remember, because aluminium won't soak up water, your Highfield will weigh the same in 10 years as it did the day it left the showroom.

The environmental credentials of aluminium are impressive too. A lighter boat needs less power to propel it through the water, which in turn requires less fuel and lowers emissions. Couple this to the fact that the hull is totally recyclable and you can see that a Highfield RIB is an environmentally sound choice.

To ensure the long life of your Highfield RIB, we only use top quality materials. High tensile, marine-grade aluminium is powder coated and baked to ensure a smooth and durable finish, which is more eco-friendly. Our tube fabrics are either Valmex® PVC from the reputed Melher Technologies in Germany, or ORCA® Hypalon, from the standard bearer in commercial tube design, Pennel and Flipo in France.

Every Highfield boat is rigorously tested to strict ISO standards before leaving the factory. This comprehensive testing of all of our component parts during manufacture, and our 2 year structural warranty\* on all of our boats, means you can have complete confidence in your Highfield RIB.

## Australian design



Aluminium boats have been the first choice of Australians for a very long time. This choice has enabled Australian boats to withstand the rough and tumble of the turbulent waters, rocky coastline and coral sand beaches. All Highfield boats are designed and developed in Australia using the best expertise available.

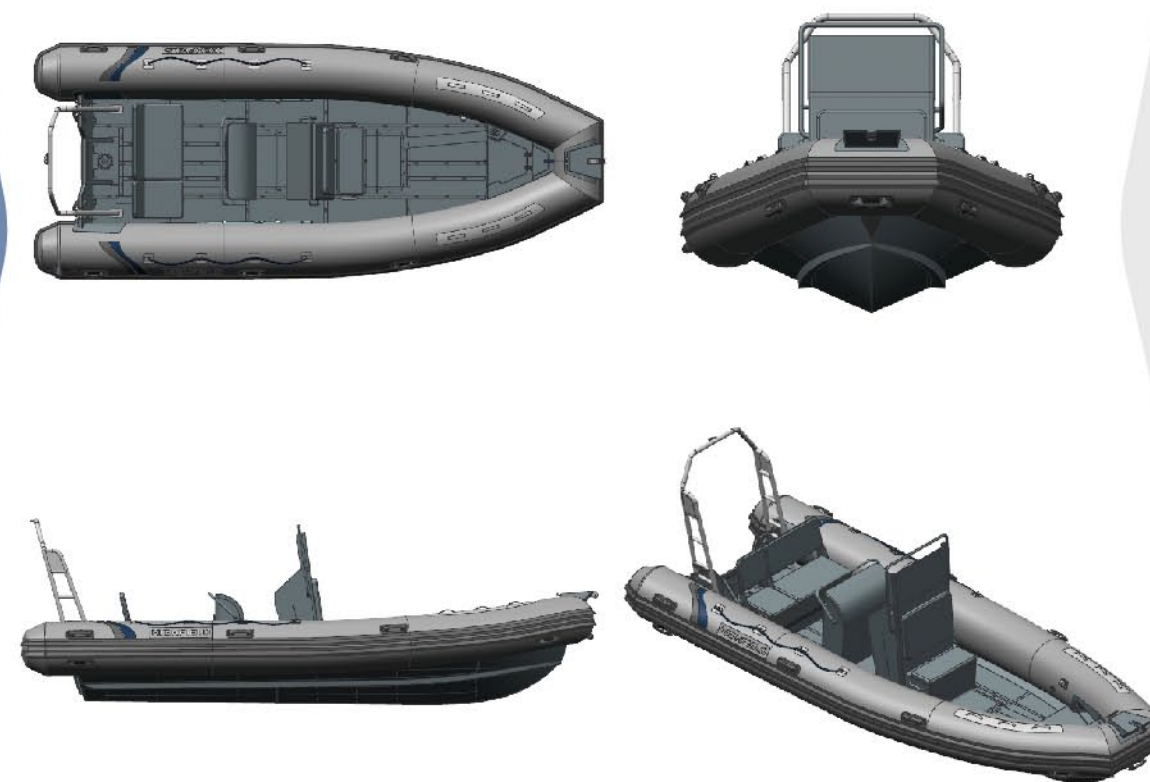

### ULTRALITE RANGE

UL 240 / 260 / 290 / 310 / 340 p4

### CLASSIC RANGE

CL 260 / 290 / 310 p6

CL 340 / 360 / 380 p8

### CLUB RANGE

CB 390 / 420 / 460 p10

### OCEAN MASTER RANGE

OM 350 / 390 p14

OM 420 / 460 p16

OM 500 / 540 / 590 p18

### DELUXE OPTION

OM 540DL / 590DL / 640DL p20

### ROLL-UP RANGE

RU 200 / 230 / 250 / 280 p22





UL 240

**Standard equipment**

- Valmex® PVC tube fabric
- Welded seams
- Flush mount non-return valves
- High tensile chromated & powder coated aluminum hull
- Self-draining deck
- Removable seat
- Lifting points and towing eyes
- Tow bridle points
- Anti-slip deck
- Light weight rubbing strake
- Full length keel guard
- Under seat bag
- Boat cover
- Highfield dry bag
- Foot pump, oars, repair kit

**Optional equipment**

- ORCA® Hypalon tube fabric
- Dinghy wheels

# Ultralite 240/260/290/310/340

Designed and built to be light but tough and do all the things a tender should do best. Stable on water and a snack to get off the beach, they are simply the best in this role.

You will be impressed by their obvious quality level. The excellence of the finish only compares the detail of the ergonomics. The simple layout is combined with an uncluttered design and numerous standard accessories complete the picture. Because of their light weight they are a real alternative for those who may have

chosen a soft bottom tender in the past but would prefer a hard hull for its performance. Ultralite tenders are roomy and strong, yet light and easy to transport. These little boats can be launched and recovered by a single man and are easy to be transported on a roof rack.

Model	Length (A)	Beam (B)	Inside Length (C)	Inside width (D)	Weight	Deadrise (E)	Max Pax	Max Load	Max Hp	Shaft	Tube Ø	Airtight Chambers
UL 240	240 cm 7' 10"	151cm 4' 11"	166cm 5' 5"	75cm 2' 5"	25Kg 59lb	15°	3	290Kg 639lb	4	Short	38cm 15"	3
UL 260	260 cm 8' 6"	151cm 4' 11"	185cm 6' 1"	75cm 2' 5"	28Kg 64lb	15°	4	340Kg 750lb	6	Short	38cm 15"	3
UL 290	290 cm 9' 6"	151cm 4' 11"	201cm 6' 7"	75cm 2' 5"	36Kg 79lb	15°	4	375Kg 827lb	8	Short	38cm 15"	3
UL 310	318 cm 10' 5"	171cm 5' 7"	226cm 7' 5"	79cm 2' 7"	44Kg 97lb	15°	5	585Kg 1290lb	10	Short	44cm 17"	3
UL 340	348 cm 11' 5"	171cm 5' 7"	253cm 8' 4"	79cm 2' 7"	49Kg 108lb	15°	6	663Kg 1462lb	15	Short	44cm 17"	3

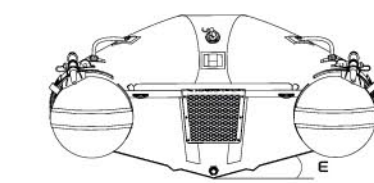
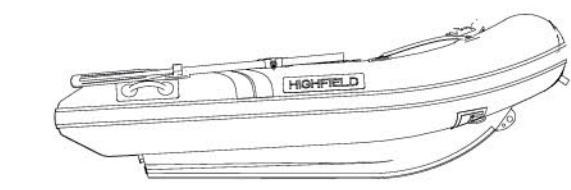
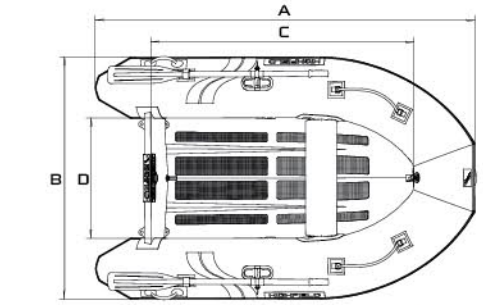





CL 290

**Standard equipment**

- Valmex® PVC tube fabric
- Welded seams
- Flush mount non-return valves
- High tensile chromated & powder coated aluminum hull
- Self-draining deck
- Integrated transom supports
- Removable seat
- Lifting points and towing eyes
- Tow bridle points
- Anti-slip deck
- Heavy duty rubbing strake
- Full length keel guard
- Tank strap kit
- Under seat bag
- Boat cover
- Highfield dry bag
- Foot pump, oars, repair kit

**Optional equipment**

- ORCA® Hypalon tube fabric
- Transom storage box
- Extra seat (Except CL260)
- Bow locker (Fit 12L fuel tank)
- Dinghy wheels
- FCT console (Except CL260)
- Molded bow cleat

# Classic<sub>260/290/310</sub>

Called the Classic range because these really are the perfect all-round tender that's also built to last.

The high quality finish and luxury look belies the fact that this range of tenders has been designed to work hard. A durable aluminium hull coupled with full length keelguards make these ideal for those beach-hopping days with friends and family.

The large weight savings achieved compared to equivalent GRP tenders means you'll enjoy impressive performance with smaller engines, and with excellent payload capacities, the Classic range really does offer a tender for everyone.

Model	Length (A)	Beam (B)	Inside Length (C)	Inside width (D)	Weight	Deadrise (E)	Max Pax	Max Load	Max Hp	Shaft	Tube Ø	Airtight Chambers
CL 260	260 cm 8' 6"	171cm 5' 7"	185cm 6' 1"	79cm 2' 7"	40Kg 88lb	15°	4	360Kg 794lb	8	Short	44cm 17"	3
CL 290	290 cm 9' 6"	171cm 5' 7"	205cm 6' 9"	79cm 2' 7"	44Kg 97lb	15°	4	480Kg 1058lb	10	Short	44cm 17"	3
CL 310	318 cm 10' 5"	171cm 5' 7"	226cm 7' 5"	79cm 2' 7"	50Kg 110lb	15°	5	550Kg 1213lb	15	Short	44cm 17"	3

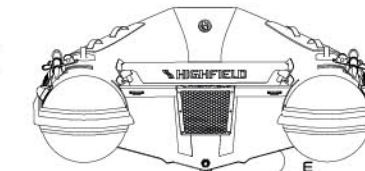
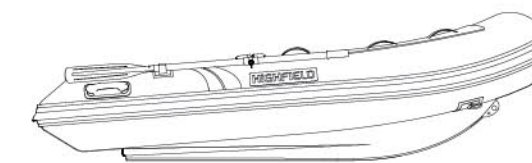
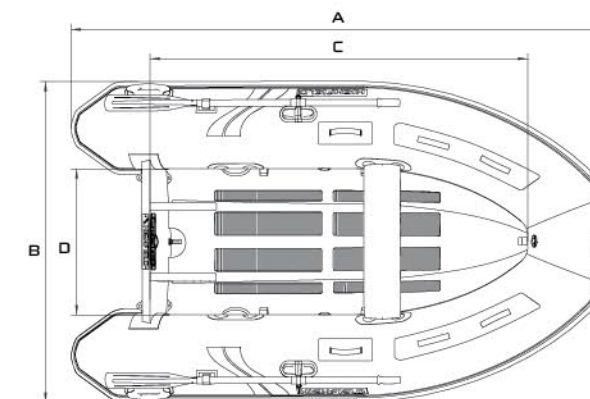





CL 360

**Standard equipment**

- Valmex® PVC tube fabric
- Welded seams
- Flush mount non-return valves
- High tensile chromated & powder coated aluminum hull
- Self-draining deck
- Integrated transom supports
- Bow locker (Fit 24L fuel tank)
- Removable seat
- Lifting points and towing eyes
- Tow bridle points
- Anti-slip deck
- Heavy duty rubbing strake
- Full length keel guard
- Tank strap kit
- Under seat bag
- Boat cover
- Highfield dry bag
- Foot pump, oars, repair kit

**Optional equipment**

- ORCA® Hypalon tube fabric
- Transom storage box
- Extra seat
- FCT console
- Dinghy wheels
- Molded bow cleat

# Classic 340/360/380

Strong, lightweight and dry riding, these boats really do all the things a tender should.

It's the details that make the difference, too. The raised floor means you'll keep your feet and kit dry, even in a very choppy sea. Davit lifting eyes are welded into the deck for easy launching and towing, and heavy duty rubbing strakes will give you peace of mind when coming back alongside. Console options are available from CL340 upwards making the Classic an easy handling fun runabout for when you've anchored in a bay for lunch.

Model	Length (A)	Beam (B)	Inside Length (C)	Inside width (D)	Weight	Deadrise (E)	Max Pax	Max Load	Max Hp	Shaft	Tube Ø	Airtight Chambers
CL 340	348 cm 11' 5"	171cm 5' 7"	253cm 8' 4"	79cm 2' 7"	61Kg 134lb	15°	6	620Kg 1367lb	20	Short	44cm 17"	3
CL 360	366 cm 12'	171cm 5' 7"	273cm 8' 11"	79cm 2' 7"	66Kg 146lb	15°	6	650Kg 1433lb	25	Short	44cm 17"	3
CL 380	380 cm 12' 6"	171cm 5' 7"	290cm 9' 6"	79cm 2' 7"	71Kg 157lb	15°	7	690Kg 1521lb	25	Short	44cm 17"	3

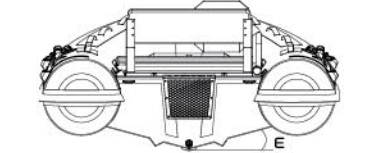
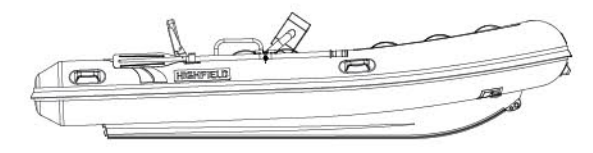
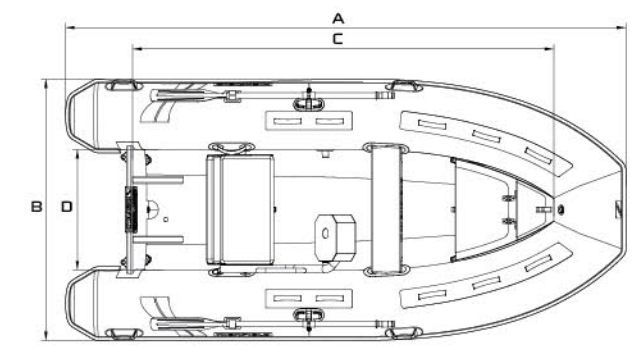

Drawings show optional FCT console







CB 420

**Standard equipment**

- Valmex® PVC tube fabric
- Welded seams
- Flush mount non-return valves
- High tensile chromated & powder coated aluminum hull
- Self-draining deck
- Integrated transom supports
- Molded bow cleat
- Bow locker (Fit 24L fuel tank)
- Lifting points and towing eyes
- Tow bridle points
- Anti-slip deck
- Heavy duty rubbing strake
- Full length keel guard
- Tank strap kit
- Highfield dry bag
- Foot pump, paddles, repair kit

**Optional equipment**

- ORCA® Hypalon tube fabric
- Boat cover
- Seat
- Under seat bag
- Transom storage box

# CLUB<sub>390/420/460</sub>

Typically Highfield, the Club boats are just the toughest boats of these weights on the market. They offer a safe deep deck and a lot of room at a very attractive price.

The Club boats are a range of well balanced and very responsive crafts, designed for load carrying and that will bring you a lot of fun on the water. Take them to the rough, thanks to their 20" dead rise the Club range will handle impeccably and quickly instill a high degree of confidence.

Model	Length (A)	Beam (B)	Inside Length (C)	Inside width (D)	Weight	Deadrise (E)	Max Pax	Max Load	Max Hp	Shaft	Tube Ø	Airtight Chambers
CB 390	390cm 12' 9"	185cm 6' 2"	285cm 9' 4"	93cm 3'	90kg 198lb	20°	7	700kg 1543lb	30	Long	47cm 18"	3
CB 420	420cm 13' 9"	208cm 6' 10"	320cm 10' 6"	110cm 3' 7"	106kg 234lb	20°	8	755kg 1664lb	40	Long	47cm 18"	4
CB 460	460cm 15' 1"	208cm 6' 10"	360cm 11' 10"	110cm 3' 7"	115kg 254lb	20°	9	995kg 2194lb	40	Long	47cm 18"	5

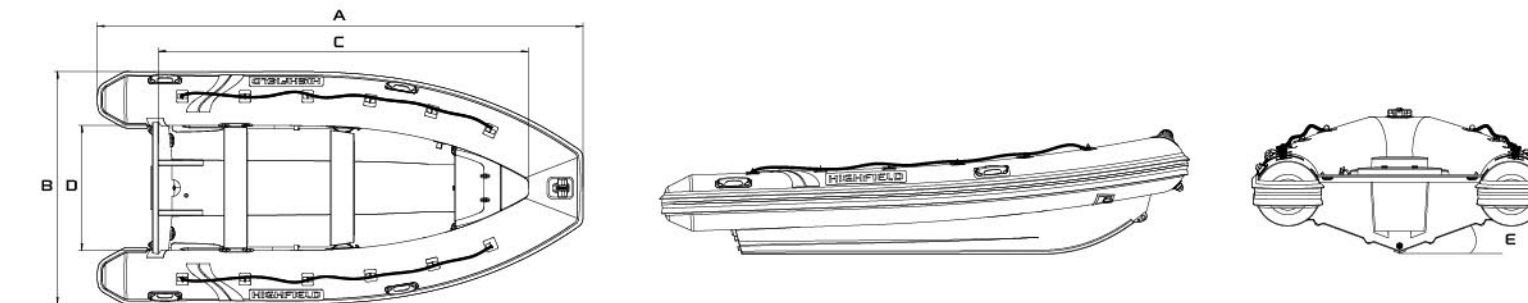









OM 350

**Standard equipment**

- Valmex® PVC tube fabric
- Welded seams
- Flush mount non-return valves
- High tensile chromated & powder coated aluminum hull
- Integrated transom supports
- Bow step with mooring cleat and roller
- Bow locker with seat cushion
- Lifting points and towing eyes
- Tow bridle points
- Anti-slip deck
- Heavy duty rubbing strake
- Full length keel guard
- Highfield dry bag
- Foot pump, paddles, repair kit

**Optional equipment**

- ORCA® Hypalon tube fabric
- Sitdown console and seat
- Boat cover
- Transom storage box
- 35L fitted fuel tank with gauge (bow locker)

# Ocean Master 350/390

Go anywhere, in any weather knowing you're in safe hands.

Ocean Master 350 and 390 are fabulous family cruising RIB or luxury tender. Whatever layout you choose, you can be assured that your Ocean Master is built to last. The Ocean Master range is designed with harsh conditions in mind. Integrated fuel tank, non-slip deck and a 20" dead rise let you take on even the roughest conditions confidently. With the impermeable qualities of our aluminium hulls there's no need to worry about gelcoat

chips, or putting the boat on a beach or a trailer. Your Highfield Ocean Master won't delaminate over time, retaining its agile performance and weighing the same in 10 years time as the day you towed it away from the showroom. All Ocean Master RIBs are easy to trail, easy to launch recover due to their light weight and integrated davit lifting eyes.

Model	Length (A)	Beam (B)	Inside Length (C)	Inside width (D)	Weight	Deadrise (E)	Max Pax	Max Load	Max Hp	Shaft	Tube Ø	Airright Chambers
OM 350	350cm 11' 6"	185cm 6' 1"	253cm 8' 3"	92cm 3'	92kg 203lb	20°	6	680kg 1499lb	40	Long	47cm 18"	3
OM 390	390cm 12' 10"	185cm 6' 1"	285cm 9' 4"	92cm 3'	112kg 247lb	20°	7	780kg 1720lb	50	Long	47cm 18"	3

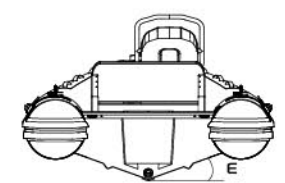
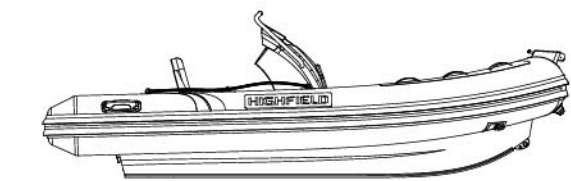
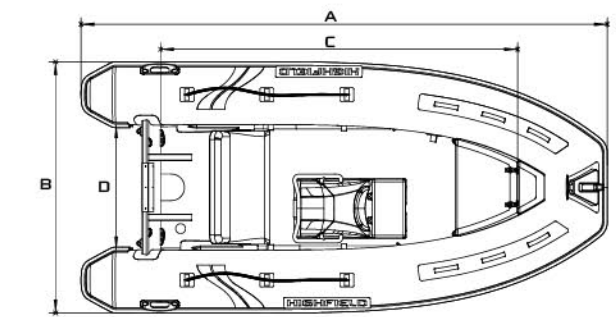





OM 460

**Standard equipment**

- Valmex® PVC tube fabric
- Welded seams
- Flush mount non-return valves
- High tensile chromated & powder coated aluminum hull
- Integrated transom supports
- Self-draining deck
- Integrated under-deck fuel tank (45L)
- Bow step with mooring cleat and roller
- Bow locker with seat cushion
- Lifting points and towing eyes
- Tow bridle points
- Anti-slip deck
- Heavy duty rubbing strake
- Full length keel guard
- Highfield dry bag
- Foot pump, paddles, repair kit

**Optional equipment**

- ORCA® Hypalon tube fabric
- Sitdown console and seat
- Standup console
- Bolster seat
- Boat cover
- Transom storage box
- Roll bar
- Navigation lights

# Ocean Master 420/460

The Ocean Master range is engineered to last, the most capable and seaworthy RIBs for their size on the market.

Ocean Masters 420 and 460 designs offer fitting options that create either a fabulous family cruising RIB, a luxury tender or a hard working support vessel. Whatever layout you choose, you can be assured that your Ocean Master is built to last. The Ocean Master range is designed with tough conditions in mind. Internal under-deck fuel tanks, non-slip deck, self-draining deck and a 20° dead rise let you take on even the toughest conditions confidently.

With the impermeable qualities of our aluminium hulls there's no need to worry about gelcoat chips, or putting the boat on a beach or a trailer. Your Highfield Ocean Master won't delaminate over time, retaining its agile performance and weighing the same in 10 years time as the day you towed it away from the showroom. All Ocean Master RIBs are easy to trail, easy to launch and recover due to their light weight and integrated davit lifting eyes.

Model	Length (A)	Beam (B)	Inside Length (C)	Inside width (D)	Weight	Deadrise (E)	Max Pax	Max Load	Max Hp	Shaft	Tube Ø	Airtight Chambers
OM 420	420cm 13' 9"	210cm 6' 11"	320cm 10' 6"	108cm 3' 6"	140kg 308lb	20°	8	850kg 1874lb	60	Long	47cm 19"	4
OM 460	460cm 15' 1"	210cm 6' 11"	360cm 11' 10"	108cm 3' 6"	170kg 375lb	20°	9	900kg 1984lb	80	Long	47cm 19"	5

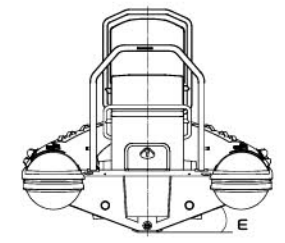
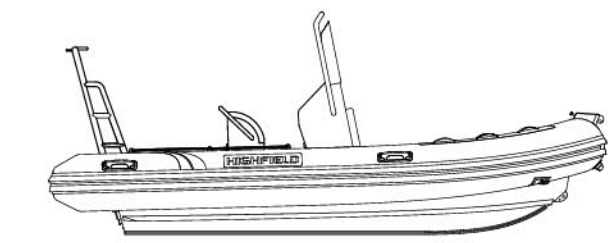
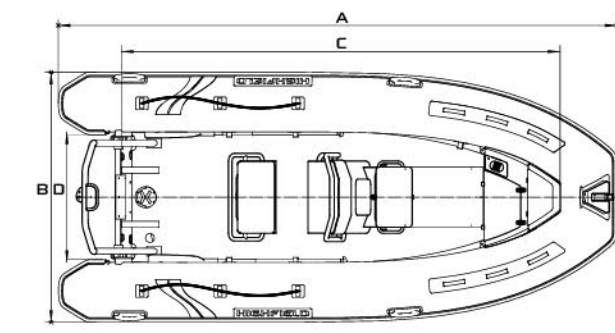





OM 590

# Ocean Master 500/540/590

Built to tick all the boxes no matter what you have in mind, Ocean Masters are just the toughest.

With models ranging from 5.0 to 5.9 metres, the flexibility and adaptability of the Ocean Master design offers fitting options that create either a fabulous family cruising RIB, a luxury tender or a hard working support vessel. Whatever layout you choose, you can be assured that your Ocean Master is built to last. The Ocean Master range is designed with tough conditions in mind. Internal under-deck fuel tanks, non-slip deck, self-draining deck and a 24° dead rise let you take on even the toughest conditions confidently.

With the impermeable qualities of our aluminium hulls there's no need to worry about gelcoat chips, or putting the boat on a beach or a trailer. Your Highfield Ocean Master won't delaminate over time, retaining its agile performance and weighing the same in 10 years time as the day you towed it away from the showroom.

All Ocean Master RIBs are easy to trail, easy to launch and recover due to their light weight and integrated davit lifting eyes. Even the largest OM590 can be towed on an unbraked trailer.

## Standard equipment

- Valmex® PVC tube fabric
- Welded seams
- Flush mount non-return valves
- High tensile chromated & powder coated aluminum hull
- Integrated transom supports
- Self-draining deck
- Integrated under-deck fuel tank
- Bow step with mooring cleat and roller
- Bow locker with seat cushion
- Lifting points and towing eyes
- Anti-slip deck
- Heavy duty rubbing strake
- Full length keel guard
- Highfield dry bag
- Foot pump, paddles, repair kit

## Optional equipment

- ORCA® Hypalon tube fabric
- Sitdown console and seat
- Standup console
- Bolster seat
- Boat cover
- Transom storage box
- Roll bar
- Navigation lights

Model	Length (A)	Beam (B)	Inside Length (C)	Inside width (D)	Weight	Deadrise (E)	Max Pax	Max Load	Max Hp	Shaft	Tube Ø	Airtight Chambers	Fuel Tank						
OM 500	500cm	16' 1"	230cm	7' 10"	385cm	12' 7"	120cm	4' 3"	310kg	683lb	24°	10	1000kg 2204lb	90	Long	52cm	20"	6	90L
OM 540	540cm	17' 8"	238cm	7' 10"	428cm	14'	130cm	4' 3"	340kg	750lb	24°	12	1200kg 2645lb	115	Long	52cm	20"	6	105L
OM 590	590cm	19' 4"	244cm	8'	483cm	15' 10"	130cm	4' 3"	380kg	838lb	24°	14	1400kg 3086lb	140	Long	55cm	22"	6	120L

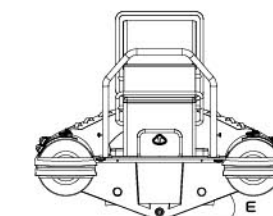
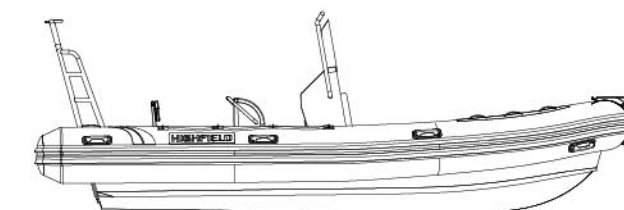
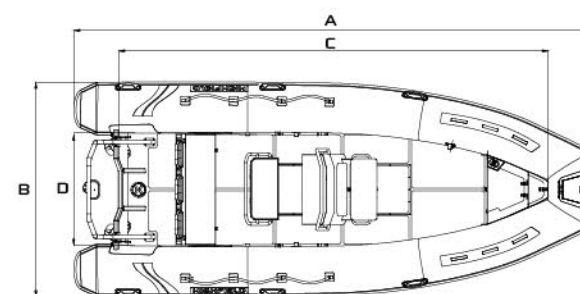





OM 640 DL

**Standard equipment**

- Valmex® PVC tube fabric
- Welded seams
- Flush mount non-return valves
- High tensile chromated & powder coated aluminum hull
- Integrated rear seat with cushion
- Self-draining deck
- Integrated under-deck fuel tank
- Bow step with mooring cleat
- Bow locker with seat cushion
- Lifting points and towing eyes
- Anti-slip deck
- Engine well
- Heavy duty rubbing strake
- Keel guard
- Highfield dry bag
- Foot pump, paddles, repair kit

**Optional equipment**

- ORCA® Hypalon tube fabric
- Standup console
- Bolster or jockey seat
- Boat cover
- Roll bar
- Navigation lights

# Ocean Master DL 540/590/640

Deluxe series, take it to the next level.

Based on the recognized hull of the OM range, the DL series reveal a more elaborated transom with integrated rear seat and engine well. This new setup offers a vast storage and higher level of confort for family cruising. Available on the OM 540 & 590, this new series also boast the brand new 640 model. Built to last, the series is designed with tough conditions in mind.

With the impermeable qualities of our aluminium hulls there's no need to worry about gelcoat chips, or putting the boat on a beach or a trailer. Your Highfield Ocean Master won't delaminate over time, retaining its agile performance and weighing the same in 10 years time as the day you towed it away from the showroom.

Model	Length (A)	Beam (B)	Inside Length (C)	Inside width (D)	Weight	Deadrise (E)	Max Pax	Max Load	Max Hp	Shaft	Tube Ø	Airtight Chambers	Fuel Tank
OM 540	540cm 17' 8"	238cm 7' 10"	370cm 12' 1.5"	130cm 4' 3"	390kg 860lb	24°	12	1200kg 2645lb	115	XL	52cm 20"	6	105L
OM 590	590cm 19' 4"	244cm 8'	425cm 13' 11.5"	130cm 4' 3"	430kg 948lb	24°	14	1400kg 3086lb	140	XL	55cm 22"	6	120L
OM 640	643cm 21' 1"	245cm 8'	460cm 15' 1"	130cm 4' 3"	480kg 1058lb	24°	16	1600kg 3527lb	175	XL	56cm 22"	6	150L

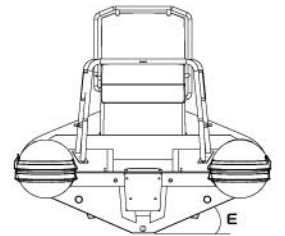
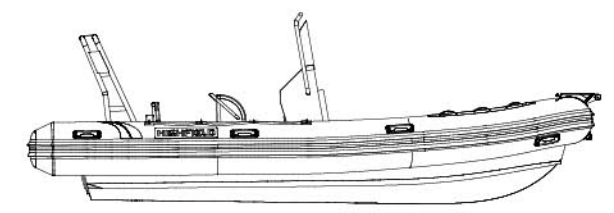
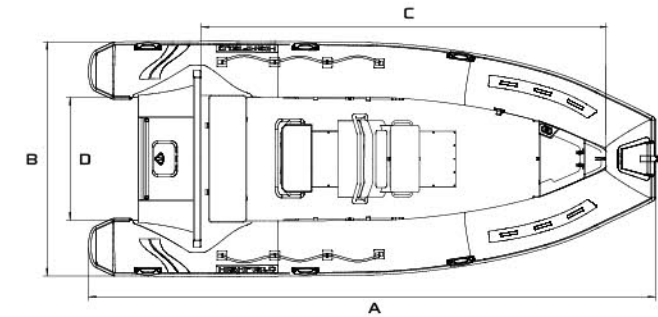





RU 230

**Standard equipment**

- Valmex® PVC tube fabric
- Welded seams
- Flush mount non-return valves
- High tensile chromated & powder coated-aluminum transom
- Self-draining deck
- Removable seat
- Lifting points and towing eyes
- Slatted or airmat floor with keel
- Light weight rubbing strake
- Full length keel guard
- Foot pump, oars, repair kit

**Optional equipment**

- DRCA® Hypalon tube fabric
- Under seat bag

# Roll-up 200/230/250/280

Highfield innovative aluminum transom takes the inflatables to the next level. Compact and economical, these boats are ideal as ship-to-shore tender.

Model	Length (A)	Beam (B)	Inside length (C)	Inside width (D)	Net weight	Max pax	Max load	Max HP	Shaft	Tube Ø	Airight chambers
RU 200 SL	200cm 6' 7"	117cm 3' 10"	130cm 4' 3"	50cm 1' 8"	17kg 37lb	2	250kg 550 lb	3.5	Short	34cm 13"	2
RU 230 SL	230cm 7' 7"	131cm 4' 9"	152cm 5'	60cm 2'	19kg 42lb	2	350kg 770 lb	4	Short	36cm 14"	3
RU 250 SL	250cm 8' 2"	152cm 5'	155cm 5' 1"	68cm 2' 3"	22kg 49lb	3	450kg 990 lb	6	Short	42cm 16"	3
RU 280 SL	280cm 9' 2"	152cm 5'	166cm 5' 5"	68cm 2' 3"	26kg 57lb	4	500kg 1100 lb	10	Short	42cm 16"	3
RU 200 AM	200cm 6' 7"	117cm 3' 10"	130cm 4' 3"	50cm 1' 8"	15kg 33lb	2	250kg 550 lb	3.5	Short	34cm 13"	2
RU 230 AM	230cm 7' 7"	131cm 4' 9"	152cm 5'	60cm 2'	17kg 37lb	2	350kg 770 lb	4	Short	36cm 14"	3
RU 250 AM	250cm 8' 2"	152cm 5'	155cm 5' 1"	68cm 2' 3"	20kg 44lb	3	450kg 990 lb	6	Short	42cm 16"	3
RU 280 AM	280cm 9' 2"	152cm 5'	166cm 5' 5"	68cm 2' 3"	23kg 51lb	4	500kg 1100 lb	10	Short	42cm 16"	3

